

Eagle 336L Wired Cabinet

DATA SHEET



DESCRIPTION

The Eagle model 336L cabinet assembly and auxiliary equipment meets CalTrans specifications per the 2009 TEES. The cabinet assembly measures 46" high x 24" wide and a depth of 20".

The 336L cabinet assembly provides control for up to eight vehicle phases and four pedestrian phases. Two doors enable access from either side to provide easy maintenance. All surfaces are bare unpainted aluminum. Anodizing and/or painting is available per request. A police door with a Signal On/Off switch and Flash/Auto switch is included with each cabin. Each cabinet can also include options such as cabinet light(s), door alarm, detector test pan red monitoring board and more.

STANDARD FEATURES

- 16 detector channel capability
- 2 or 4 channel detector modules
- 2 R/R Preemption input (AC isolation)
- 4 emergency vehicle inputs (input file slots 10 & 11)
- DC isolation inputs for pedestrian push buttons and special functions
- High-efficiency, switching power supply. Programmable yellow/red or all red flash through the use of color-coded flash plugs.
- 2 dual circuit flasher positions
- Solid state relay for flash control
- Surge suppressor/ Line filter and 30A main circuit breaker mounted on service panel assembly (SPA) for incoming power
- Thermostatically controlled ventilation system with 100 CFM fan.

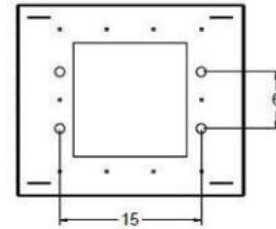
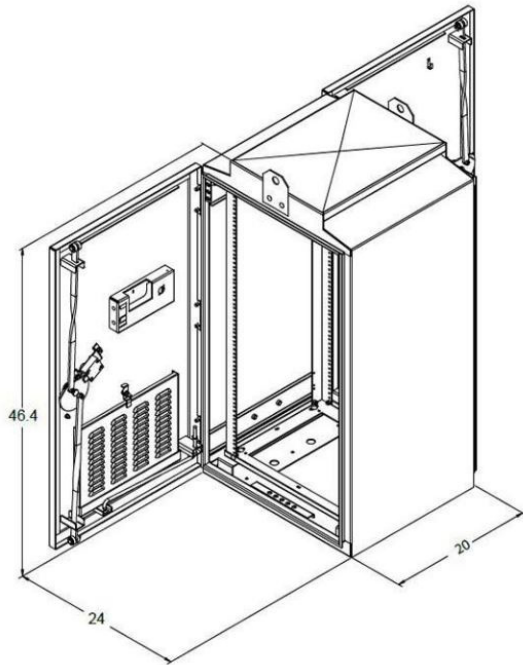

DIMENSIONS

46" H x 24" W x 20" D

STANDARD ENCLOSURE SPECIFICATIONS

Completely fabricated from 1/8" thick type 5052-H32 vinyl-coated, mill-finished aluminum utilizing continuously welded construction.

Door openings double flanged on all sides.

Thermoconvection air ventilation systems utilized with provisions for mounting fan for forced-air cooling.

Exhaust outlet openings provided under roof.

All internal and external hardware utilizes non-corrosive material.

Automatic door stop can be latched at 90° and 180° positions.

Furnished with internal E.I.A. 19" rack for mounting equipment.

COMMON OPTIONAL FEATURES

Cabinet lights.

Detector and preempt test switch panel.

Red monitoring kit.

Manual control cable located in police panel.

Pull out drawer/shelf

22" deep cabinet for additional clearance on the front and back of the 19" rack

STANDARD DOOR SPECIFICATIONS

Provided with three-point locking mechanism with duplex nylon rollers, top and bottom.

3/4" diameter stainless steel inward-turning handles with provisions for padlocking.

Main door lock – industrial standard pin tumbler lock with #2 key.

Louvered inlet with filter to prevent dirt from entering with air flow.

Closed-cell neoprene door seal gasket.

Stainless steel leave hinges with .190" diameter stainless steel hinge pins. Pin ends are welded to the hinge and ground smooth. Hinge pins and bolts are covered by the door edge and not accessible when the door is closed.

A fabricated switch compartment is included with a standard police lock and a stainless steel continuous hinge with a 1/8" diameter hinge pin carriage bolted in place. Compartment mounted flush to the side wall.

ORDERING INFORMATION

ELS336L – Cabinet with Rack

JBS2336LTCA01 – Terminal Facility – CalTrans Standard