

Eagle 334L Wired Cabinet

DATA SHEET



DESCRIPTION

The Eagle model 334L cabinet assembly and auxiliary equipment meets CalTrans specifications per the 2009 TEES. The cabinet assembly measures 67" high x 24" wide and a depth of 30".

The 334L cabinet assembly is ideal for ramp metering and other applications such as a fiber optic hub, CCTV, irrigation, and sign control. Two doors enable access from either side to provide easy maintenance. All surfaces are bare unpainted aluminum. Anodizing and/or painting is available per request. A police door with a Lights On/Off switch and a Control On/Off switch is included with each cabinet. Each cabinet can also include options such as cabinet light(s), door alarm and more.

STANDARD FEATURES

- › 28 detector channel capability
- › 2 or 4 channel detector modules
- › PDA# 3L combined output file and power distribution assembly. Includes sockets for Model 206L power supply, Model 208 monitor, and 3 load switches.
- › Pull out drawer/shelf
- › Surge suppressor/Line filter and 30A main circuit breaker mounted on service panel assembly (SPA) for incoming power
- › Thermostatically controlled ventilation system with 100 CFM fan

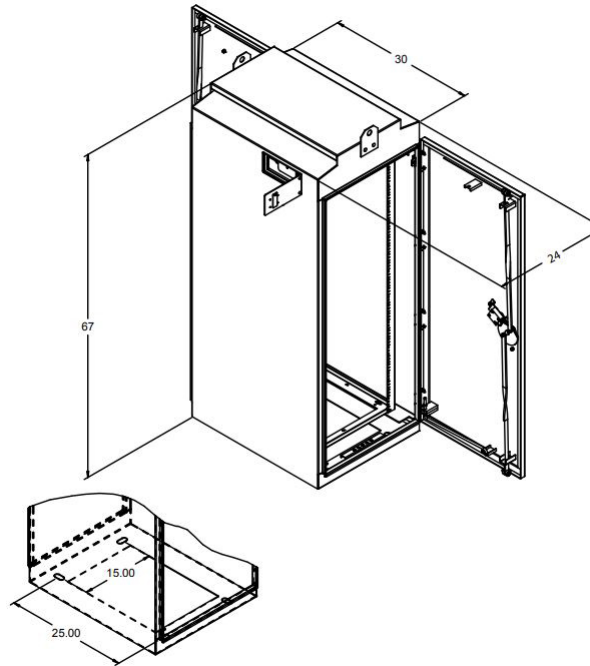

DIMENSIONS

67" H x 24" W x 30" D

STANDARD ENCLOSURE SPECIFICATIONS

Completely fabricated from 1/8" thick type 5052-H32 vinyl-coated, mill-finished aluminum utilizing continuously welded construction.

Door openings double flanged on all sides.

Thermoconvection air ventilation systems utilized with provisions for mounting fan for forced-air cooling.

Exhaust outlet openings provided under roof.

All internal and external hardware utilizes non-corrosive material.

Automatic door stop can be latched at 90° and 180° positions.

Furnished with internal E.I.A. 19" rack for mounting equipment.

COMMON OPTIONAL FEATURES

Additional input files for expanded detection.

Cabinet lights.

Door alarm switch.

Dual fans in enclosure.

Special configurations available on request.

STANDARD DOOR SPECIFICATIONS

Provided with three-point locking mechanism with duplex nylon rollers, top and bottom.

3/4" diameter stainless steel inward-turning handles with provisions for padlocking.

Main door lock – industrial standard pin tumbler lock with #2 key.

Louvered inlet with filter to prevent dirt from entering with air flow.

Closed-cell neoprene door seal gasket.

Stainless steel leave hinges with .190" diameter stainless steel hinge pins. Pin ends are welded to the hinge and ground smooth. Hinge pins and bolts are covered by the door edge and not accessible when the door is closed.

A fabricated switch compartment is included with a standard police lock and a stainless steel continuous hinge with a 1/8" diameter hinge pin carriage bolted in place. Compartment mounted flush to the side wall.

ORDERING INFORMATION

ELS3322L – Cabinet with Rack

JBS2334LTCA01 – Terminal Facility – CalTrans Standard